

- 02 OWNER'S MANUAL
- 03 ILLUSTRATIONS
- 04 CONNECTIONS
- 06 SETUP & USAGE
- 09 SPECIFICATIONS
- 10 TROUBLESHOOT



Owner's manual

Dear Customer,

Quality has always been our driving force and founding Argon Audio is a natural extension of this philosophy. We have 20 years' experience in creating and specifying high quality products, manufacturing them and selling them on to end users with Value-for-Money as the primary aim. And Argon Audio is a brand fully compliant with these values.

Design, features and quality standards are all specified in Denmark and manufacturing takes place in the Far East, where quality vendors are highly competitive - and as a result supply outstanding Value-for-Money products – to the delight of both ourselves and our customers!

Introduction

Thank you for choosing Argon Audio TT-2 Turntable, we hope it will bring you many years of enjoyment. Please read this manual fully before unpacking and installing the product.

Maintenance and cleaning

Your record player requires little or no regular maintenance. Remove dust with a slightly moistened antistatic cloth. Never use a dry cloth because this will create static electricity which attracts more dust! Antistatic cleaning fluids are available at specialist stores but must be applied sparingly to avoid damage to rubber parts. It is recommended to fit the needle cover before cleaning or maintenance is carried out to avoid damage.

If the player is not used over a long period of time the drive belt can be removed to prevent unequal stretching. *Always disconnect the record player from the mains power supply as a precaution before maintenance!*

Useful tips

The record player should be positioned on a low-resonance surface such as wood or multiple layer ply board to avoid structural vibrations disturbing replay.

Environmental information

Argon TT2 complies with international directives on the Restriction of Hazardous Substances (RoHS) in electrical and electronic equipment and the disposal of Waste. Electrical and Electronic Equipment (WEEE) - the crossed bin symbol indicates compliance and that the products must be appropriately recycled or processed in accordance with these directives.

Safety instructions

Please store this instruction manual for future reference. Do not use this product near water or moisture. Place the unit on a solid surface. Do not block any ventilation openings. Do not put it in a closed bookcase or a cabinet that may keep air from flowing through its ventilation openings. Do not install near any heat sources, such as radiators, heat registers, stoves or other appliances that produce heat. Protect the power cord from being walked on or pinched, particularly at plugs and the point where they exit from the product. Servicing is required when the product has been damaged. Do not attempt to service this product yourself. Opening or removing covers may expose you to dangerous voltages or other hazards.

Please contact the manufacturer to be referred to an authorized service center near you. To prevent risk of fire or electric shock, avoid over loading wall outlets, extension cords, or integral convenience receptacles. Do not let objects or liquids enter the product. Use proper power sources. Plug the product into a proper power source, as described in the operating instructions or as marked on the product.

Unpacking

We have during production and packing carefully checked and inspected this Turntable.

After unpacking please check for any damage from transport.

We recommend that you keep the original carton box and packing material for any future shipping.

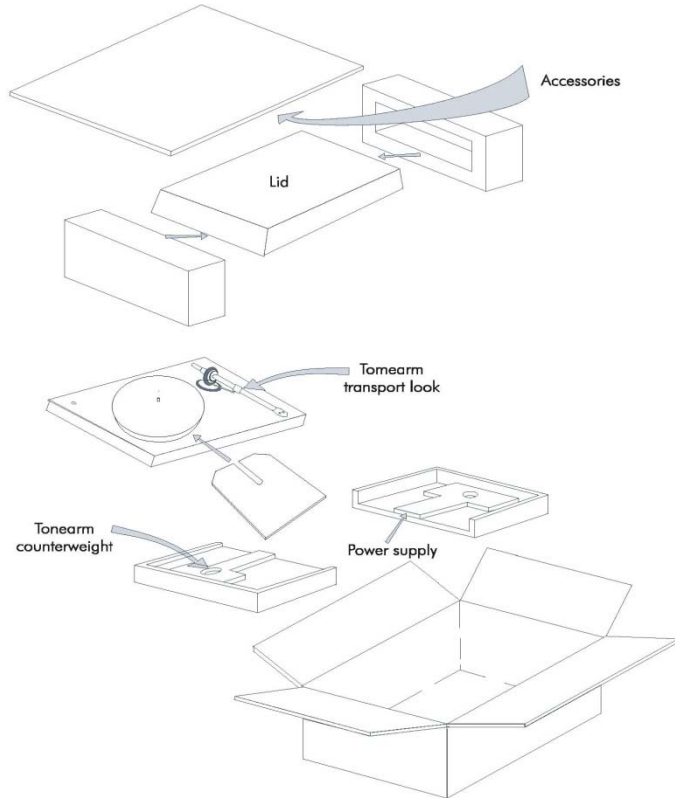

Controls, features and connections

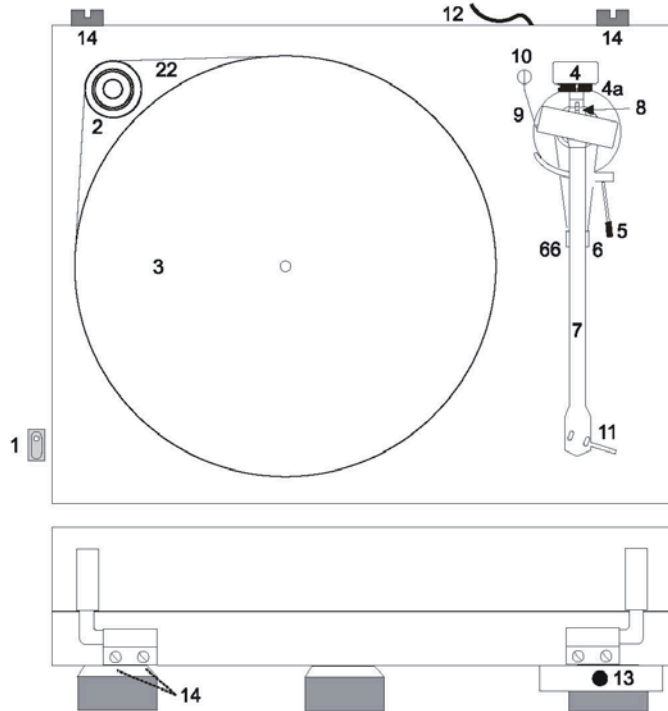

Controls, features and connections

- 1 Power switch
 - 2/22 Stepped drive pulley and drive belt
 - 3 Platter with felt mat
 - 4/4a Tonearm counterweight - 4a Downforce scale
 - 5 Tonearm lift lever
 - 6/66 Tonearm rest and removable transport lock
 - 7 Tonearm tube
 - 8 Anti-skating weight adjustment scale
 - 9 Anti-skating weight support hoop
 - 10 Anti-skating weight with wire
 - 11 Headshell with finger lift and fitted Ortofon OM 5E cartridge
 - 12 Signal output cable
 - 13 Power supply socket (on USB version in middle)
 - 14 Lid hinges with Hinge fasteners
- *Power supply not shown

Connections especially for USB version

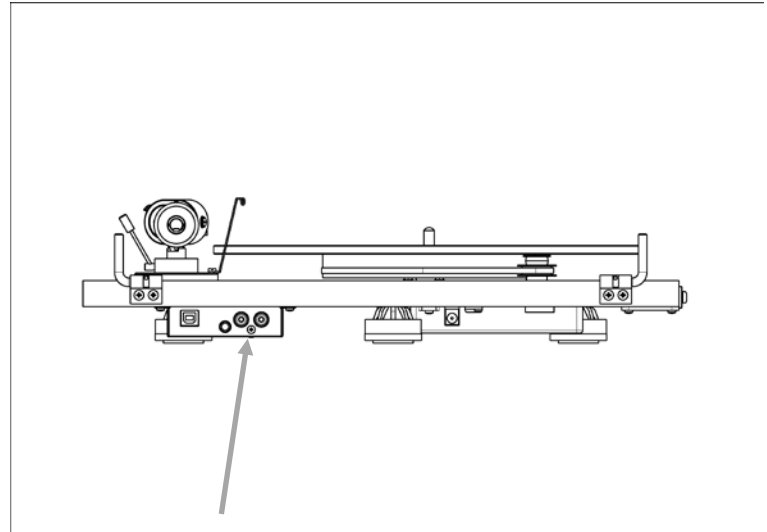

Compared to the non-USB version, the USB version has connectors on the back.

The RCA cable and the ground cable have to be connected to the turntable. Whereas on the Non-USB version the RCA cable is mounted on the turntable. USB connection is also on the back of the USB version.

Setup and usage

In order to achieve maximum performance and reliability with this record player you should study these instructions for use carefully.

The Argon Audio TT2 record player is supplied with a factory fitted and adjusted cartridge.

During assembly and adjustment of the deck, small parts could be lost if not carefully placed in a suitable receptacle.

Before starting assembly make yourself acquainted with the parts listed above and correspondingly numbered in the technical drawings above.

Set-up

Make sure the surface you wish to use the turntable on is level (use a spirit level) before placing the turntable on it.

Fit the drive belt (2/22) around the hub (2/22) and the smaller diameter part of the motor pulley (2/22). Avoid getting sweat or grease on the belt as these will deteriorate the performance and reduce the belt's lifespan. Use absorbent kitchen paper to remove any oil or grease from the outer edge of the hub and the belt. Fit the platter (3) and felt mat over the spindle of the hub (2/22).

Cartridge down force adjustment

Adjusting the down force and anti-skating if you are not familiar with it can be complicated. We recommend that you watch the following video for your convenience. [YouTube video for adjusting down force and anti skating on a turntable \(click here\).](#)

The counterweight (4) supplied is suitable for cartridges weighing between 3,5 - 5,5g. An alternative counterweight for cartridges weighing between 6 - 9g is available as an accessory part. Adjust the down force prior to installing the anti-skating weight.

Gently push and turn the counterweight (4) onto the arm tube stub. Lower the arm lift and position the cartridge in the space between arm rest and platter. Carefully rotate the counterweight (4) until the arm tube balances out. The arm should return to the balanced position if it is moved up or down. This adjustment must be done carefully. Do not forget to remove the cartridge protection cap if fitted.

Once the arm is correctly balanced return it to the rest. Hold the counterweight (4) without moving it, and gently revolve the down force scale ring (4a) until the zero is in line with the anti-skating prong (8). Check whether the arm still balances out.

Rotate the counterweight counter clockwise (seen from the front) to adjust the down force according to the cartridge manufacturer's recommendations.

One mark on the scale represents 1 mN (= 0,1g / 0,1 Pond) of downforce.

The recommended downforce for the factory fitted cartridge is 17,5mN

Anti-skating force adjustment

The anti-skating force must be adjusted according to the mass of the cartridge as follows:

<u>Downforce</u>	<u>Groove in the stub (8)</u>
10 - 15mN	1 st from bearing rings
15 - 20mN	2 nd " " "
20mN and bigger	3 rd " " "

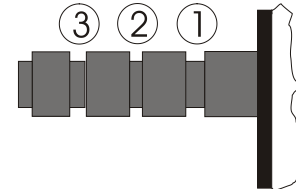

Slip the loop of the anti-skating weight's thread over the second groove of the stub to set the correct anti-skating force for the factory-fitted cartridge. Feed the thread through the loop of the wire support (10).

Connection to the amplifier

The Argon Audio TT2 has a captive tonearm signal lead (12) for connection to the amplifier. Use the Phono input (sometimes labelled gram, disc or RIAA) on your amplifier. Make sure that the phono input offers correct matching and amplification for the type of cartridge used. Line inputs (such as CD, Tuner, Tape or Video) are not suitable.

Take care to connect the left and right channels correctly. The right channel is usually marked red, the left channel black or white. Check the manual supplied with your amplifier for relevant information. The earthing wire of the tonearm lead should be connected to the earth terminal on your amplifier (if provided).

If your amplifier does not have an input suitable for phono cartridges you will require a separate phono amplifier stage for MM or MC cartridges such as the PRO-JECT PHONO BOX, the NAD RIAA AMP or the CAMBRIDGE RIAA AMP, which is then connected between the record player and a free line level input of the amplifier.

NOTICE. Argon Audio TT2 USB version has build in RIAA AMP

The recommended load resistance for the factory fitted cartridge is: 47kohms/MM-input

Mains power connection

The turntable is supplied with a power supply suitable for your country's mains supply. Check the label before connecting to ensure compliance with the mains rating in your house.

Connect the low voltage plug from the power supply to the socket (13) on the rear of the record player before connecting the power supply to the mains.

Fitting the lid

Fit the lid carefully over the hinge fasteners and adjust the screws (14) until the lid stays open where you want it to without being too stiff to open or close.

Switching on and off

Pressing the power switch (1) alternately starts or stops the motor.

Changing replay speed

To play records at 45 r.p.m. first remove the platter (3). Using the accessory tool provided, hook the belt over the larger diameter part of the motor pulley (2/22). Refit the platter. To revert to 33,33 r.p.m. repeat the proceedings using the smaller step on the pulley.

Fitting and connecting the cartridge

** All cartridges with half inch mounting holes can be fitted. Leaving the needle's protection cover on, fit the cartridge to the headshell using the screws supplied with the cartridge by passing one screw through each slot in the headshell (11). Do not tighten the nuts yet.

Connect the tonearm wires to the cartridge pins as follows:

white	left channel positive (L+)
red	right channel pos. (R+)
green	right channel return (R -)
blue	left channel return (L -)

The full sound quality of the Argon Audio TT2 can only be achieved if the cartridge is correctly adjusted.

If you are not well acquainted with the adjustment of cartridges you are advised to call upon the willing help of your Argon Audio dealer to accomplish this task for you.

Technical specifications Argon Audio TT2

Nominal speeds	33,33/45,11 r.p.m..
Speed variance	±0,8 %
Wow and flutter	±0,12 %
Signal to noise	-65dB
Downforce range	10 - 30mN
Effective tonearm length	8,6 " (218,5mm)
Overhang	18,5mm
Power consumption	2W
Outboard power supply	16V/500mA AC, suitable for your country's mains supply
Dimensions (W x H x D)	415 x 118 x 320mm, dust cover open 415 x 365 x 405mm
Weight	5,5kg
USB Version specific	Build in RIAA AMP

Technical specifications ORTOFON OM 5E

Frequency response	20Hz - 20kHz	Recommended load resistance	47kohms
Channel balance	<2dB	Amplifier connection	MM -input
Channel separation	>22dB	Recommended tracking force	17,5mN
Output voltage	4mV	Weight	5g

Troubleshoot - Potential incorrect use and fault conditions

Argon Audio turntables are manufactured to the highest standards and undergo strict quality controls before leaving the factory. Faults that may possibly occur are not necessarily due to material or production faults but can sometimes be caused by incorrect use or unfortunate circumstances. Therefore the following list of common fault symptoms is included.

The platter doesn't turn although the unit is switched on:

- The unit is not connected to the mains power supply.
- No mains at the socket.
- Drive belt is not fitted or has slipped off.

No signal through one or other channel or both channels:

No signal contact from the cartridge to the internal tonearm wiring or from that to the arm lead or from that to the phono box or between that and the amplifier. This could be due to a faulty plug, broken wire or solder joint or simply loose plug/socket connection.

- Phono input not selected at amplifier.
- Amplifier not switched on.
- Amplifier or speakers defective or muted.
- No connection to the loudspeakers.

Strong hum on phono input:

- No earth connection from cartridge or arm or arm cable to amplifier, or earth loop.

Distorted or inconsistent sound from one or both channels:

- Record player is connected to wrong input of amplifier, or MM/MC switch incorrectly set.
- Needle or cantilever damaged.
- Wrong r.p.m., drive belt overstretched or dirty, platter bearing without oil, dirty or damaged.